



Holiday Living & Design® is a registered trademark of LF, LLC. All Rights Reserved.

ITEM #0069658

4.5 FT PRE-LIT BRISTEN PINE TREE

MODEL #W14F0391

Español p. 8

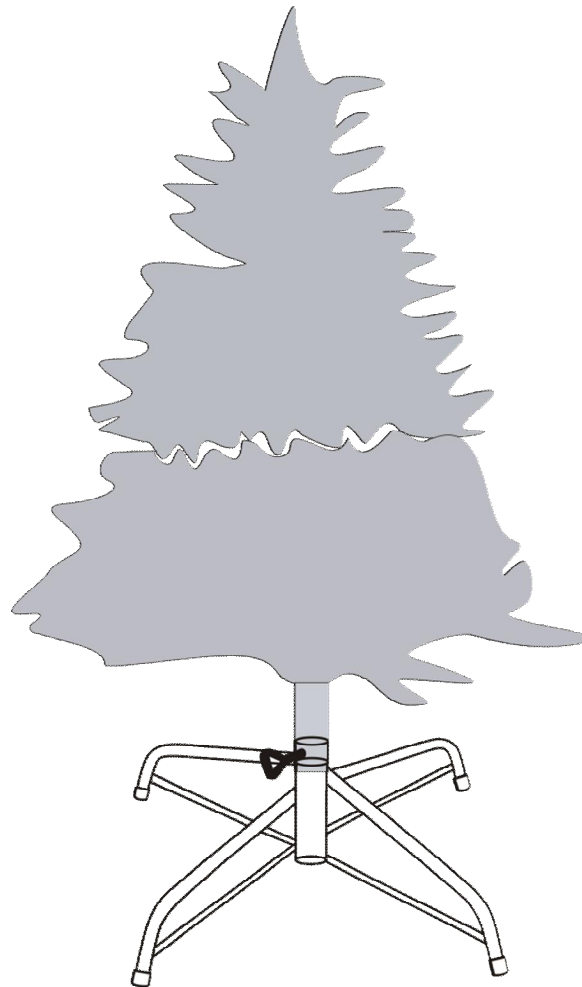

Questions, problems, missing parts? Before returning to your retailer, call our customer service department at 1-800-643-0067, 8 a.m. - 6 p.m., EST, Monday - Thursday, 8 a.m. - 5 p.m., EST, Friday.

AB1371

PACKAGE CONTENTS

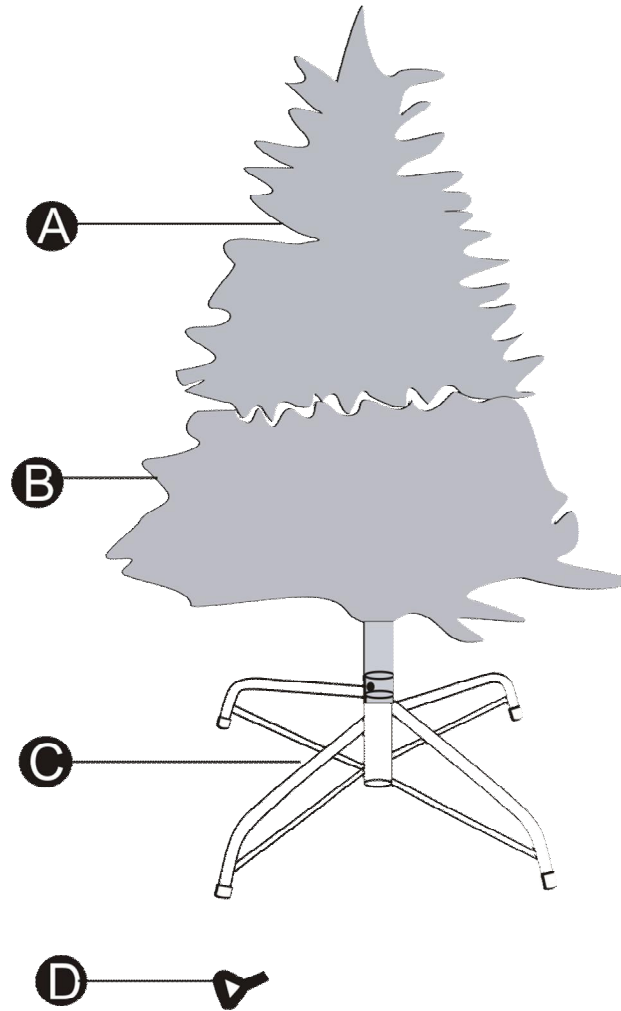

PART	DESCRIPTION	QUANTITY
A	Top Section	1
B	Bottom Section	1
C	Base	1
D	Screw	1

SAFETY INFORMATION

Please read and understand this entire manual before attempting to assemble, operate or install the product.

WARNING

To reduce the risk of electric shock or injury:

Do not plug in the unit before assembly.

Keep electric wires clear of being pinched or cut during assembly or installation. Discard sets with cut or damaged insulation.

For indoor and outdoor use.

RISK OF FIRE

Do not replace attachment plug. Do not remove the safety device (fuse). Discard product if the attachment plug is damaged.

CAUTION

- To reduce the risk of overheating, replace burned-out bulbs promptly. Use 2.5 volt bulbs only.
- This lighting is rated 81.6 watts (0.68 amps). Do not overload. Connect other lighting string or decorative outfits end-to-end up to a maximum of 210 watts (1.75 amps) total.
If connecting to a lighting string that does not have a Wattage (W) rating { found on the tag within 6 inches of the plug } calculate the wattage as follows: Multiply the current (0.68 A) which is on the flag-type tag by 120.
For example: Lighting string is rated 120V, 60Hz, 0.68Amps. $0.68 \times 120 = 81.6$ Watts
TOTAL AMOUNT OF WATTAGE THAT CAN BE CONNECTED $210W - 81.6W = 128.4W$

When using electrical products, basic precautions should always be followed including the following:

READ AND FOLLOW ALL SAFETY INSTRUCTIONS

- Do not use seasonal products outdoors unless marked suitable for indoor and outdoor use. When products are used in outdoor applications, connect the product to a Ground Fault Circuit Interrupting (GFCI) outlet. If one is not provided, contact a qualified electrician for proper installation.
- This seasonal-use product is not intended for permanent installation or use.
- Do not mount or place near gas or electric heaters, fireplaces, candles or other similar sources of heat.
- Do not secure the wiring of the product with staples or nails, or place on sharp hooks or nails.
- Do not let lamps rest on the supply cord or on any wire.
- Unplug the product when leaving the house, when retiring for the night, or if left unattended.
- This is an electric product – not a toy! To avoid risk of fire, burns, personal injury and electric shock it should not be played with or placed where small children can reach it.
- Do not use this product for other than its intended use.
- Do not hang ornaments or other objects from cord, wire or light string.
- Do not close doors or windows on the product or extension cords as this may damage the wire insulation.
- Do not cover the product with cloth, paper or any material not part of the product when in use.
- This product is equipped with push-in type bulbs. Do not twist bulb.
- This product employs overload protection (fuse). A blown fuse indicates an overload or short-circuit situation. If the fuse blows, unplug the product from the outlet. Also unplug any additional strings or products that may be attached to the product. Replace the fuse as per the User Servicing Instructions (follow product marking for proper fuse rating) and check the product. If the replacement fuse blows, a short-circuit may be present and the product should be discarded.
- Read and follow all instructions that are on the product or provided with the product.

SAVE THESE INSTRUCTIONS

PREPARATION

Before beginning assembly of product, make sure all parts are present. Compare parts with package contents list and diagram above. If any part is missing or damaged, do not attempt to assemble, install or operate the product.

Estimated Assembly Time: 20 minutes

No tools required for assembly.

ASSEMBLY INSTRUCTIONS

1. Place the base (C) on a level surface. Unfold the base (C) and insert the screw (D) into the hole.

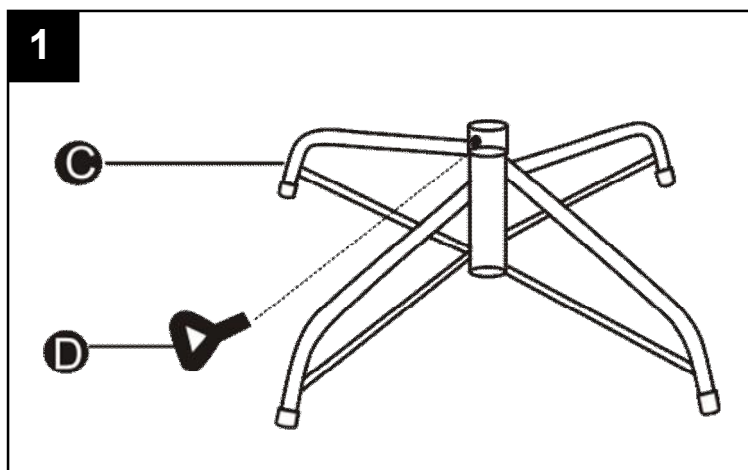

2. Insert the bottom section (B) into the base (C) and secure it with the screw (D).

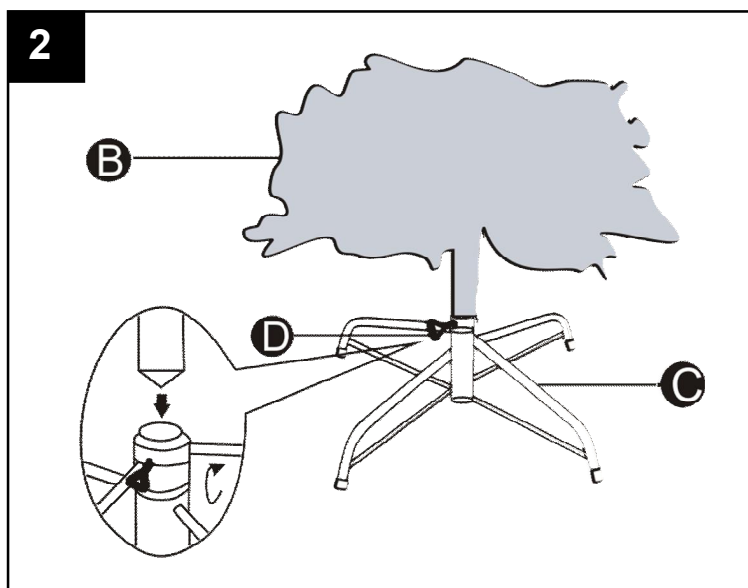

3. Insert the top section (A) into the bottom section (B).

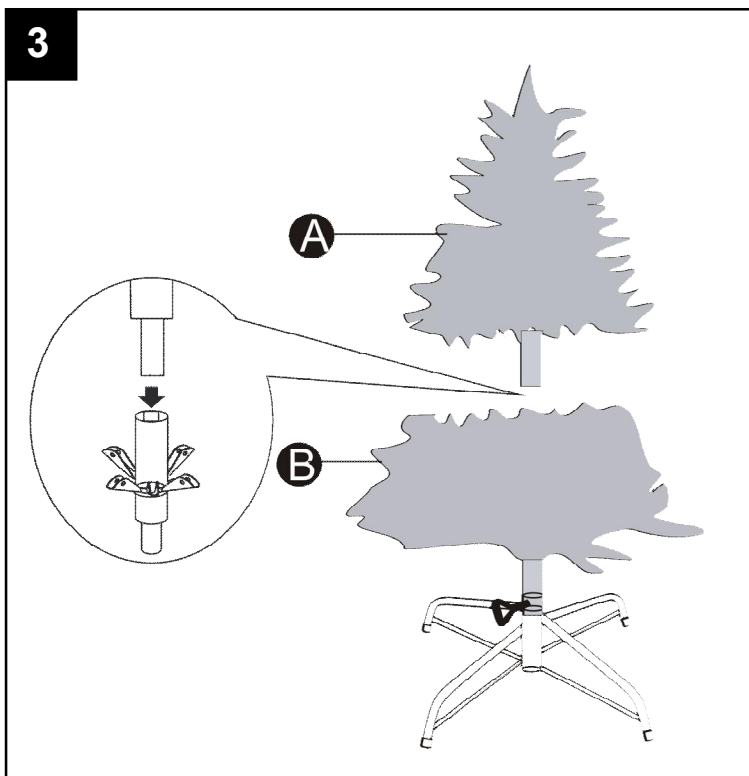

4. Connect plug of the top section (A) with end connector of bottom section (B).

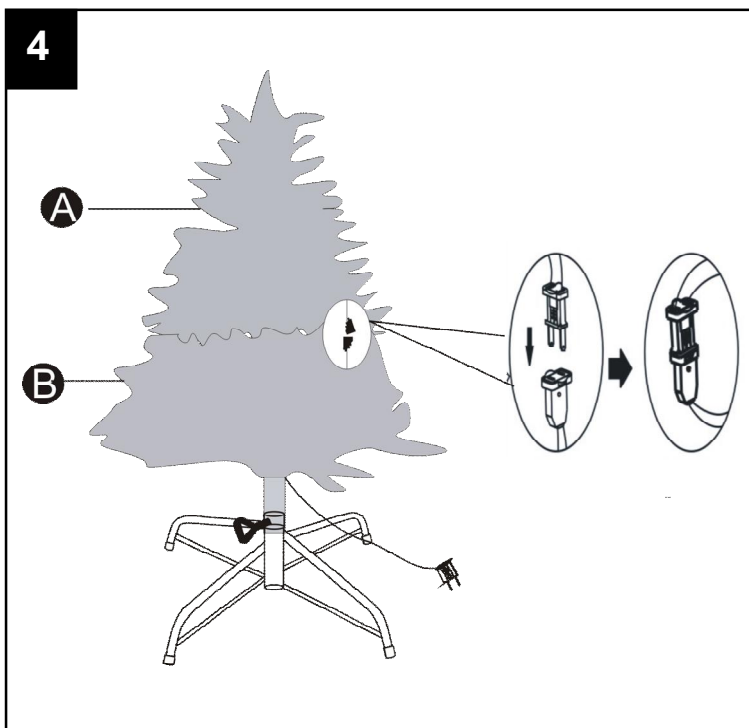

5. Open all the branches.

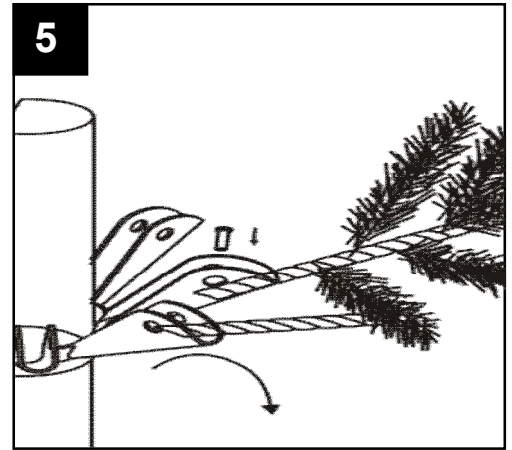

6. Shape the branches. Starting with tips farthest from the trunk, spread one to the right, one to the left and one at the center of the main stem. Plug electrical cord into a properly grounded outlet.

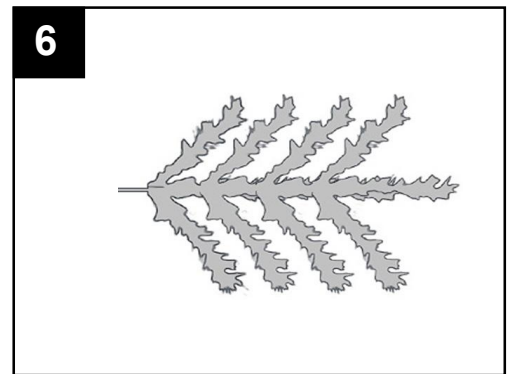

USER SERVICING INSTRUCTIONS

Replace the fuse.

- Grasp plug and remove from the receptacle or other outlet device. Do not unplug by pulling on the cord.
- Open fuse cover. Slide open the fuse access cover on top of attachment plug toward blades.
- Remove fuse carefully.
- Risk of fire. Replace with only a 3 Amp, 125 volt fuse (provided with product).
- Close fuse cover. Slide close the fuse access cover on top of attachment plug.

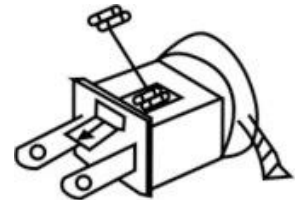

Replace the lamp.

- Grasp plug and remove from the receptacle or other outlet device. Do not unplug by pulling on the cord.
- Pull bulb and plastic base straight out of lampholder.
- Replace with only a 2.5 volt, 0.425 watt super bright type bulb (provided with product).

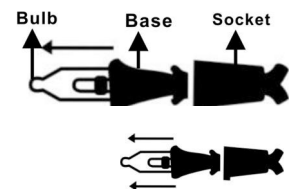

If the new lamp base does not fit in lampholder, follow these steps:

- Remove the base of burned out bulb by straightening lamp leads, and gently pull bulb out.
- Thread leads of new bulb through holes in old base with one lead in each hole.
- After bulb is fully inserted into base, bend each lead up so that the leads will touch the contacts inside the lampholder.

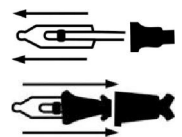

CARE AND MAINTENANCE

- Before using or reusing, inspect product carefully. Discard any products that have cut, damaged, or frayed wire insulation or cords, cracks in the lampholders or enclosures, loose connections, or exposed copper wire.
- When storing the product, carefully remove the product from wherever it is placed to avoid any undue strain or stress on the product conductors, connections, and wires.
- When not in use, store neatly in a cool, dry location protected from sunlight.

TROUBLESHOOTING

PROBLEM	POSSIBLE CAUSE	CORRECTIVE ACTION
The product does not light.	1. One or more of the bulbs are loose or out of the sockets.	1. Unplug the product. Starting with the first unlit bulb, gently push (don't twist) each bulb firmly into the socket. At the same time, look and feel for a broken bulb in the socket or an empty socket where a bulb has fallen out.
A bulb is broken.	1. The bulb was impacted or shifted during transport.	1. Mark it with a piece of tape and unplug the product before removing the bulb socket and any fragments. Replace the broken bulb. Should a light flicker while doing this, you have probably found the faulty bulb. Replace with a new bulb.
A bulb is burned out.	1. Incorrect bulb or voltage is too high.	1. The remaining bulbs will stay lit; however, it is best to replace any burned out bulbs as soon as you find them.

REPLACEMENT PARTS LIST

For replacement parts, call our customer service department at 1-800-643-0067, 8 a.m. - 6 p.m., EST, Monday - Thursday, 8 a.m. - 5 p.m., EST, Friday.

PART	DESCRIPTION	PART #
E	FUSE	W14F0391-F
F	BULB	W14F0391-B

E

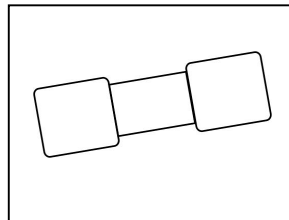

F

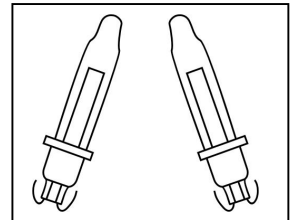

Printed in China